

## Detonation Jet Engine. Part II - Construction Features

Pavel V. Bulat<sup>a</sup> and Konstantin N. Volkov<sup>b</sup>

<sup>a</sup>Saint Petersburg National Research University of Information Technologies, Mechanics and Optics, Saint Petersburg, RUSSIA; <sup>b</sup>Kingston University, Faculty of Science, Engineering and Computing, London, UK

### ABSTRACT

We present the most relevant works on jet engine design that utilize thermodynamic cycle of detonative combustion. Detonation engines of various concepts, pulse detonation, rotational and engine with stationary detonation wave, are reviewed. Main trends in detonation engine development are discussed. The most important works that carried out theoretical, experimental and computational research and their parametrical optimization are described. Relevant for nearest time problems and directions of research are formulated.

### KEYWORDS

Detonation, detonation wave, detonation engine, rotational detonation engine, pulse detonation engine

### ARTICLE HISTORY

Received 30 April 2016  
Revised 19 June 2016  
Accepted 22 June 2016

## Introduction

The switch from Brayton thermodynamic cycle of fuel combustion at constant pressure to a more efficient Humphrey cycle of combustion at constant volume has been attempted for over more than 100 years. The example of a device that utilizes advantages of Humphrey cycle is a pulse jet engine (PJE). Nowadays the PJE is mainly used in cheap unmanned aerial vehicles (UAV), due to their simplicity. The idea of creating a PJE has been patented in 1906 by Russian engineer V.V. Karavodin. In 1930, Paul Schmidt has proposed a single-valve combustion chamber for PJE. It was later used in unmanned flying bombs of "V-1" series. A great contribution to the solution of PJE creation problem was made by B.S. Stechkin.

During first stroke of work cycle, the engine's chamber is filled with air-fuel mixture. The combustion occurs during second stroke. During third stroke, the

**CORRESPONDENCE** Pavel V. Bulat ✉ [pavelbulat@mail.ru](mailto:pavelbulat@mail.ru)

© 2016 Bulat and Volkov. Open Access terms of the Creative Commons Attribution 4.0 International License (<http://creativecommons.org/licenses/by/4.0/>) apply. The license permits unrestricted use, distribution, and reproduction in any medium, on the condition that users give exact credit to the original author(s) and the source, provide a link to the Creative Commons license, and indicate if they made any changes.

combustion front runs through combustion chamber, increasing pressure inside of it at constant volume. At fourth stroke the work medium expands performing useful work. During fifth and sixth stroke, the combustion chamber is purged with fresh air.

Despite the high energy conversion efficiency of fuel combustion itself, the total useful work of PJE is significantly lower than that of gas turbine engine (GTE). It is because the compression of air-fuel mixture occurs in simple isentropic compression waves that are relatively long. As a result the pulse occurrence frequency of PJE is rather low which results in low energy conversion efficiency. The detonation engine utilizes a cycle that is similar to Humphrey cycle. The typical constructions of detonation engines and the tendencies in their development are reviewed below.

This review continues a series of authors' works on detonation engines (Bulat & Ilina, 2013; Bulat & Prodan, 2013; Bulat, 2014).

### Literature Review

The logical development of PJE idea is pulse detonation engine, in which compression waves are changed to shock waves. It worth to mention, despite that classic pulse detonation engine (PDE) has high thermodynamic efficiency of a single pulse, it also has all of the flaws typical for pulse jet engine: low pulse occurrence frequency of shock waves and as a result low integral thrust efficiency.

The most basic case of PDE is a pipe filled with fuel and oxidizer mixture (Nicholls, Wilkmsom & Morrison, 1957). The mixture detonation is initiated at the start of each cycle with powerful enough energy source. The pulse occurrence frequency varies between 10 and 100 Hz. The injectors of fuel and oxidizer are located at the seal end of the pipe. After pipe is filled with a mixture the detonation is initiated at the open or sealed end of the pipe. The pressure caused by detonation product on sealed end produces thrust. In set of cases the nozzle is not required at all. The velocity of detonative piston exceeds the speed of conventional combustion by an order of two. The cycle frequency is varied via independent detonation initiation using controlled ignition system.

After the mixture ignition the combustion transition to detonation occur at significant distance from sealed end, and detonation wave velocity doesn't immediately reach the value of established Chapmen-Jouguet detonation (Levin et al., 1998; Eidelman & Grossman, 1992). The mixing of fuel and oxidizer doesn't occur instantly, and thus the special measures to reduce the mixing time are required.

The difference of actual PDE cycle from an ideal one (Fig. 2) consists in that the pipe is only partially filled with combustion mixture, and detonation initiation is not instant and takes some time. The maximum values of pressure and detonation velocity are lower than that of an ideal cycle. Pipe purge from combustion products takes time, and as a result the residue from previous cycle dilutes combustible mixture, lowering the detonation wave intensity of next cycle.

In addition, the detonation engine based on traditional detonative pipes, have inherently low pulse occurrence frequency (below 100 Hz), and as a result the time during which combustion occur is low, compared to characteristic time



of the cycle. Thus, despite high energy conversion efficiency of the combustion itself, the total integral energy conversion efficiency of PDE is low.

Quasi-stationary and two-dimensional non-stationary models, designed to study work cycle of pulse detonation engine, has been formulated in V.V. Mitrofanov & S.A. Zhdan's, work (2004). The formula of specific impulse is derived, and calculations of engine thrust characteristics were carried out. At flight Mach numbers below 3.6 and compressions rate lower than 80 the engine thrust characteristics appear to be higher than that of a ramjet with subsonic combustion. With increase of compression rate the advantage of pulse detonation engine gradually decreases.

The detailed study of detonation initiation and maintenance in PDE, that uses hydrocarbon fuel, are carried out in the works (Schauer et al., 2005; Schauer, Stutrud & Bradley, 2001; Ting, Bussing & Hinkey, 1995). The establishment of self-maintaining detonation wave requires the reduction of distance at which deflagration to detonation transition (DDT) occurs. The DDT in gas mixture was studied in numerous works (Helman, Shreeve & Eidelman, 1986; Yageta, Shimada & Matsuoka, 2011; Zhukov & Starikovskii, 2005). To speed up the transition the spirals and obstructions are installed into the pipe, which leads to intensification of turbulent transfer, and also the wall perforation is conducted.

The size of pulse engine widely varies, and their functioning if permitted at low and high Mach numbers. The design complexity consists of the requirement of fast combustion chamber filling with fuel-oxidizer mixture and fast purge of combustion products. The heat exchange and friction losses are usually taken into account when detonation occurs in relatively long pipes. For instance, at length to diameter ratio of  $L/D=50$  the specific impulse equals to 90% of the theoretic value (Kawane et al., 2011).

The main goal of the modern stage is to develop engines with shock wave occurrence frequency in combustion chamber.

One of the simple solutions is a switch from one detonation pipe to an assembly of multiple pipes (Fig. 1).



**Figure 1.** A model of multi-piped PDE

With such engine setup in all detonation chamber the process queue is cycled. The process phase shift in different detonation chamber reduces pulsing of jet thrust and noise.

The alternative direction is a resonant engine. In work of V.A. Levin, Yu.I. Nechaev & A.I. Tarasov (2001) is a description of a device, which doesn't have mechanic valves and controlled ignition system. The pulse process is realized via excitement of resonant high-frequency oscillation in gas-dynamic resonator (Fig. 2) that is periodically filled with air-fuel mixture, and heat emission occurs in over compressed detonation wave formed in a resonator (Larionov, Nechaev & Mokhov, 2007). Based on model tests carried out at Institute of Mechnaics of the Moscow State University the optimization of device's geometric size and parameters has been conducted.

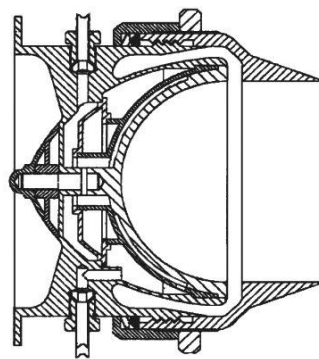


Figure 2. Thrust module of resonant PDE

### ***Aim of the Study***

The main aim is to highlight history of works on creation of fundamentally new engines that utilize thermodynamic cycle of detonative combustion.

### ***Research questions***

To present the most relevant works on jet engine design that utilizes thermodynamic cycle of detonative combustion;

To review detonation engines of various concepts, pulse detonation, rotational and engine with stationary detonation wave;

To discuss main trends in detonation engine development;

To describe the most important works that carried out theoretical, experimental and computational research and their parametrical optimization;

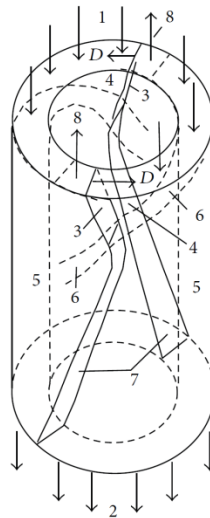
To formulate relevant for nearest time problems and directions of research.

### ***Method***

#### ***Rotational detonation engines***

The Continuous Detonation Wave Engine (CDWE) or Rotational Detonation Engine (RDE) that work not in a pulse but continuous mode, are the alternative to PDE. It seems, that Nichols was first to think of making the detonation wave

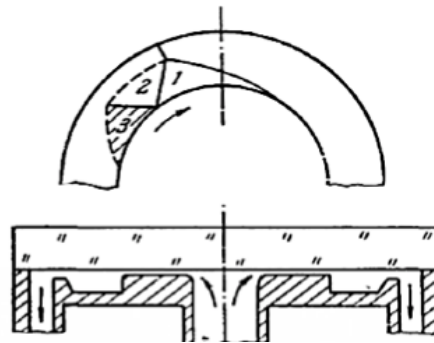
to circle (Nicholls, Wilkmsom & Morrison, 1957). He proposed jet engine construction, that consisted of two coaxial cylindrical channels (Fig. 3). From one end in between to cylinder the fuel mixture 1 is supplied, and combustion products 2 are removed from the other end. At the initial moment the detonation wave 3 is initiated, which moves circularly ( $\rightarrow D$ ) between two cylinders. The wave ignites fresh fuel mixture 4, which detonates and combusts in coaxial gap 6. The fuel mixture and combustion products are separated by tangential discontinuity 6. The interaction between detonation wave and tangential discontinuity generates an oblique wave that drags behind combustion product toward engine's exits. The outflow of combustion products creates jet thrust.



**Figure 3.** A schematic of Nichols RDE

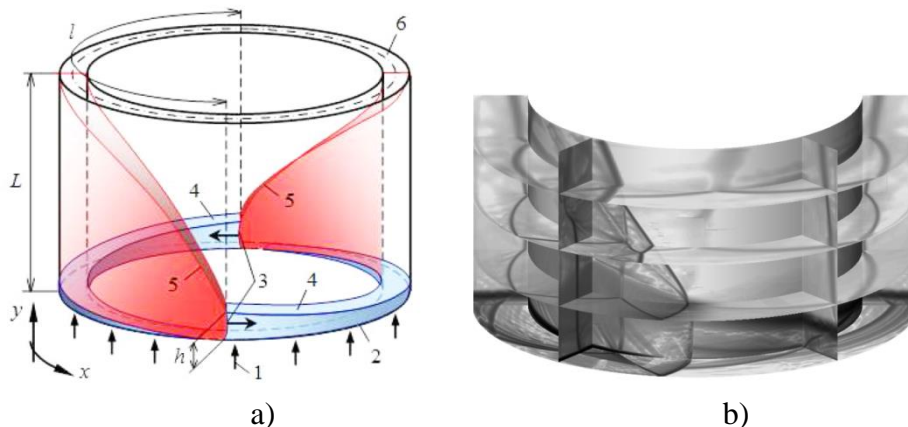
To maintain stationary detonation wave its necessary for fuel and oxidizer mixture to form before the detonation wave finishes a full circle.

At the hydro-dynamics institution Siberian Branch of Russian Academy of Sciences the serial experiments has been conducted, and B.V. Voitsekhovskiy, V.V. Mitrofanov & M.E. Topchiyan (1963) has acquired stable rotational detonation (the kerosene was used as a fuel). Based on the result of these experiments the concept of B.V. Voitsekhovskiy rotational engine was proposed (Voitsekhovskiy, Mitrofanov & Topchiyan, 1963). The engine consisted of a disk with a cylindrical gorge, covered by a transparent glass on top. The fuel mixture was supplied through a central channel, and combustion products were removed from sides (Fig. 4). During experiment it was found, the scheme of shock wave structure proposed by Nichols was incorrect. The combustion occurs not in a straight detonation wave, but in sequence of two triple shock wave configurations (Fig. 4).



**Figure 4.** A real shock wave structure in rotational detonation engine

The detonation modeling in channels with convex and concave wall was conducted in works (Lee, Cho & Choi, 2008; Pan et al., 2011), and experimental detonation research on curved channels – in a work (Nakayama et al., 2012). The most detailed numerical research of rotational detonation's quality picture was carried out by D. Davidenko, I. Gökalp & F. Falempin (2008; 2011). He discovered a complex flow structure (Fig. 5) that is similar to two-dimensional scheme of B.V. Voitsekhovskiy (Voitsekhovskiy, Mitrofanov & Topchiyan, 1963) (Fig. 4) and is completely different to Nichols's scheme (Fig. 3, 5a).



**Figure 5.** An ideal (a) and real (b) flow picture of Nichols RDE

In the ideal Nichols scheme (Fig. 5a) fresh fuel mixture (light blue) is supplied into the gap between cylinders and detonates on a straight shock wave 3, height  $h$  of which is exactly equal to the thickness of fresh fuel mixture that hasn't reacted 4. The detonation products (red) are dragged by an oblique shock wave 5 towards engine exit 6.

The real flow picture (Fig. 5b) is far more complex. The leading shock waves 3 are in fact oblique. Depending on ratios between internal and external diameters, they can be reflected from internal surface regularly or generating Mach stem. In second case the combustion occurs only on Mach stems. In the flow the secondary shock waves are also present, that generates as a result of interaction between oblique shock waves with boundary layer on walls.

Depending on combustion chamber length  $L$ , mixture pressure of mass flow and composition the various detonation modes can be observed (Kindracki,

Wolański & Gut, 2011). For detonation mode stability it is required for fuel-oxidizer mixture to occupy some length  $l$  (or volume) that is more than critical length  $l_*$ . In case of large enough combustion chamber and high mass flow the detonation mode is stable. Small combustion chamber and low mass flow lead to detonation fluctuation.

The detonation mode stability is characterized by wave number  $W = t_r / t_{mf}$ , where  $t_r = \pi d / D$  represents a time, during which a detonation wave with velocity  $D$ , makes a full circle around the cylinder of diameter  $d$ ,  $t_{mf} = V_* / V_{mix}$ . The volume of critical region is equal to  $V_* = \pi(d_0^2 - d_i^2) / 4l_*$  and volume flow of fuel-oxidizer mixture is equal to  $V_{mix} = (m_F + m_O)v_{mix}$ , and thus the wave number is obtained from the equation  $W = 2V_{mix} / l_* h D$ . The indexes  $o$  and  $i$  represent diameters of outer and inner cylinder, and indexes  $F$  and  $O$  correspond to fuel and oxidizer.

At  $W=1,2,\dots,n$  in combustion chamber there are  $1,2,\dots,n$  detonation fronts, propagating in a same direction (at pressure distribution that corresponds to one circle there is one maximum).

In case when  $W < 1$ , the detonation is unstable. After one circle around the cylinder, there won't be enough mixture to maintain the detonation, and it will start to fade. The decrease in velocity of detonation propagation leads to increase of time required for detonation front to make a full circle, which leads to volume increase of injected fuel-oxidizer mixture, which in turn increases detonation propagation velocity. The repetition of cycle leads to detonation fluctuation in combustion chamber (a galloping rotational detonation). At  $W \ll 1$  the detonation doesn't occur, and slow combustion of fuel-oxidizer mixture is observed. By varying chamber diameter and gap between cylinders for each type fuel mixture it is possible to setup a such geometry, so the combustion will be stable and cycle is repeating.

A large amount of experimental and computational research on rotational detonation, has been conducted followers of Bykovsky, S.A. Zhdan and E.F. Vedernikov (2010; 2006; 2013). They studied various fuel compositions, fuel injection designs, and flow visualization methods. This allowed proposing a concept of rotational detonation engine – demonstrator (Falempin et al., 2006).

In practice not only cylindrically shaped combustion chamber found their use, but also shaped like disks, double cones and more even complex shapes. Work of M. Hishida and P. Wolanski (2009) proposes a rotational engine setup where pretreated air and hydrogen are supplied separately, and detonation wave generation occurs not on the cylindrical surface but on the cone. The use of various hydrocarbon fuel is reviewed in a work of D. Schwer & K. Kailasanath (2013), and results of numerical calculations are compared to those of hydrogen in D. Schwer & K. Kailasanath work (2011).

The results of detonation modeling in cylindrical combustion chamber are presented in works (Schwer & Kailasanath, 2010; Shaoa, Liua & Wang, 2010; Tsuboi, Eto & Hayashi, 2007; Uemura, Hayashi & Asahara, 2013; Zhou & Wang, 2012; Zhou & Wang, 2013; Zhou, Wang & Wu, 2012).



The numerical modeling is conducted with use of non-stationary Euler equations in two- (the gap between cylinders is far smaller than chamber length and cylinder diameters) or three-dimensional approximation, ignoring the viscosity. The simple and precise models of chemical kinetics are used in calculations. In some works a relative precise grid (cell sizes is 100-250 micron) is used, that allows to solve the structure of detonation wave.

The calculations are often conducted for hydrogen-oxygen mixture, because of well-known hydrogen combustion mechanism.

The influence of combustion chamber geometry on detonation wave propagation is examined in a three-dimensional approximation, which allows to identify the flow structure in radial direction. In case when gap between the cylinders is small enough the flow in radial direction appears to be weak.

With the gap increase the specific impulse is almost constant, while jet force rises linearly.

The change of combustion chamber length leads to the appearance of not only regular reflection but also a Mach reflection of shock wave from cylinder internal surface, also the Mach stem height increases with the increase of combustion chamber length. In addition, the specific volume and jet force vary in a rather narrow range. The increase of combustion chamber's length leads to decrease of combustion products axial velocity and change of shock wave structure near frontal end of the combustion chamber.

The RDE thrust has a rather low dependency on nozzle shape, but the higher thrust is achieved with de Laval nozzle.

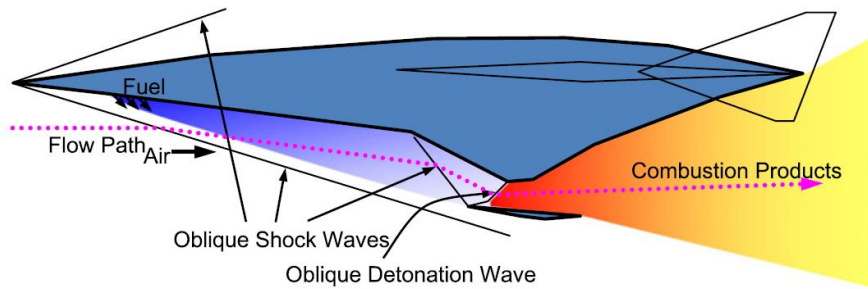
Despite more than 40 years research history of CDE and RDE, the actual result are pretty much on the level of 1964. The share of detonation combustion doesn't exceed 15% of combustion chamber volume. The rest is slow combustion at conditions worse than optimal. As a result, the specific fuel consumption per unit of thrust is 30-40% higher than that of engines with traditional design. This problem can be solved by utilizing optimal triple shock wave configurations to organize the continuous detonation.

## **Data, Analysis, and Results**

### ***Standing detonation wave engines***

The basic concept of standing detonation wave engine (SDWE) was proposed by R. Dunlap, R.L. Brehm & J.A. Nicholls (1958). The fuel is injected into supersonic flow and the detonation is stabilized by a wedge or other means. The combustion products expand in the nozzle and produce jet thrust. The engine design with formation of oblique shock wave (detonation driven ramjet or dramjet) is shown in Fig. 6.

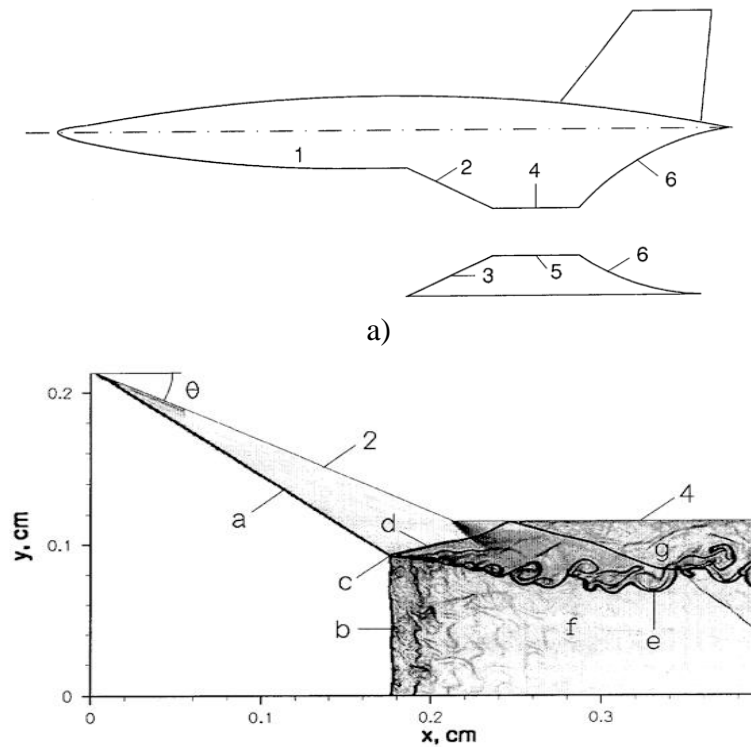




**Figure 6.** The ramjet engine design with formation of oblique shock wave

The result of numerical modeling, acquired in works (Cambier, Adelman & Menees, 1990; Jeung, Choi & Yoon, 1998) show that presented engine designs with formation of stationary shock waves, appear to function at Mach number around 5-7. Such Mach number range makes application of such engines limited.

Is it possible to create such conditions so that combustion behind the stationary shock system would also be stationary? This problem can be solved (Ivanov et al., 2006). For instance, by creating in the flow-through part of the combustion chamber (Fig. 7a) a system of symmetrically oblique incident shock waves, while in the central part of the combustion chamber cross-section, as a result of interaction between said waves, the over compressed detonation wave – Mach stem forms, height and position in the combustion chamber of which can be regulated. A detonative combustion occurs in the front of the formed detonation wave.



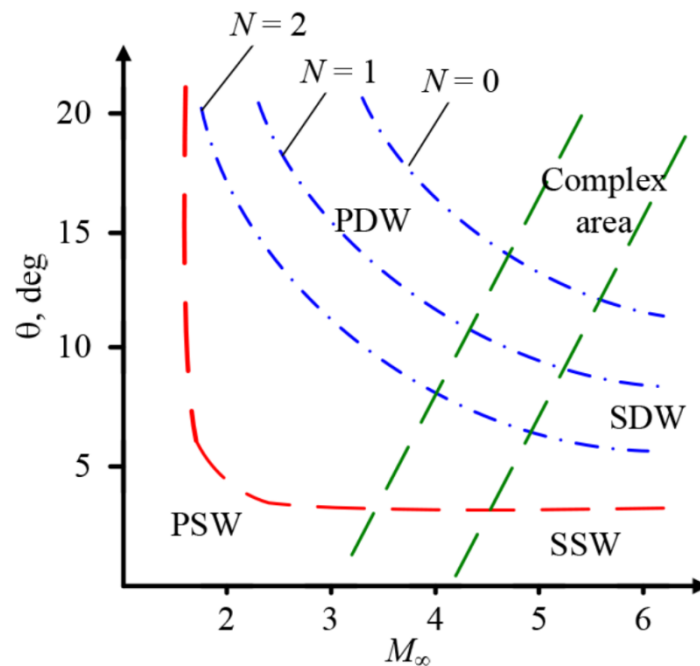
b)

**Figure 7.** A design of ramjet with straight detonation wave

1 - fuselage, 2 and 3 - wedge with adjustable slope angles, 4 - stationary wall of combustion chamber, 5 adjustable wall of combustion chamber, 6 nozzle,  $\theta$  - slope angle of surface wedge 2, a - incident shock wave, b - Mach stem, c - triple point, d - a reflect wave coming out of triple point, e - a contact discontinuity that splits flow in two in the flow-through part of the combustion chamber, f - flow of high temperature detonation that occurs in Mach stem b, g - a flow of gas mixture that didn't react "cold".

Fig. 7b shows flow structure in combustion chamber (the only upper part is presented) for model calculation of stoichiometric hydrogen-oxygen mixture flow. The Mach number of flow entering the combustion chamber is  $M = 5.5$ , static pressure is 0.2 atm.

The fuel consumption rate must be set in a way, that the Chapman-Jouguet detonation wave Mach number of formed air-fuel mixture ( $M = MCJ$ ) was lower than flow Mach number ( $M$ ) of this mixture in the inlet section of combustion chamber. The results of calculations showed, that formation of stationary Mach stem is possible starting from value of  $M = 3.15$ , and value of ratio  $M/MCJ = 1.04$  or higher. The SDWE operation modes, and dependencies on flight Mach number, wedges angle and number of oblique compression shocks ( $N-1,2,3$ ) before wave "a" are shown in Fig. 8.


**Figure 8.** Operation modes of SDWE

PDW - pulse detonation wave, PSW - pulse shock wave, SDW - standing detonation wave, SSW - stationary shock wave



At low intensity of oblique waves (low Mach numbers or low wedge angles) the detonation doesn't occur. The boundary of detonation modes is shown in Fig. 8 by red line. Non-stationary detonation modes (PDW) are separated from standing modes (SDW) by transition region that is shown in Fig. 8 by green lines. For stable operation the SDWE parameter (wedge angle and Mach number) must correspond to the region located to the right and higher of the region shown by blue line.

In Russia, the work on SDWE is conducted by ITPM and CIAM. The mathematical model of SDWE operation in pulse mode is described in a work (Alexandrov, Kraiko & Reent, 2001).

### Discussion and Conclusion

We reviewed the thermodynamic fundamentals and construction features of detonation engine of major types: pulse, rotational and standing detonation ramjets. The analysis of previous work allowed making following conclusions on the current state of the research:

- In rotational engine of Nichols or B.V. Voitsekhovskiy (Voitsekhovskiy, Mitrofanov & Topchiyan, 1963) design, the share of detonative combustion doesn't exceed 15% of combustion chamber volume. The rest of the chamber is occupied with slow combustion without shock wave which leads to unacceptable loss of total pressure. As a result the specific parameters are significantly lower than that of traditional engines operating in Brayton cycle.

- The idealization of shock wave structure, in which the combustion in detonative combustion chamber occurs, when assumed that detonation occurs in the front of straight detonation wave, doesn't match the reality even remotely. In the rotational engine the shock wave structure is two consequent triple shock wave configurations. During detonation propagation in pipe the front also is not plane, but a non-stationary continuously transforming combination of triple shock wave configuration.

- The self-maintaining detonation is characterized by the lower fuel compression rate. But for construction of an efficient heat engine, the highest possible compression rate is required, and thus its necessary to utilize over compressed detonation.

- The problem of detonation initiation and providing the shock wave occurrence with a set frequency is still relevant for PDEs.

- The direct calculation of non-stationary flows with shock and detonation wave in widespread commercial packages, based on standard difference scheme, is problematic because of strong shock waves by blurring the difference cells in first-order accuracy schemes and non-physical oscillation on shock waves in second-order accuracy schemes. In addition, during design of turbulence model the Navier-Stokes equations with averaged times are used, which describe flow of viscous gas, making it impossible from methodical point of view to calculate non-stationary shock wave process with relatively high accuracy. Thus, the new computational package must be developed, that is based on high-order difference schemes, stable on gas-dynamic discontinuity.

### Implications and Recommendations

Based on what was said above, it's possible to formulate major research direction:

Research of detonation process in rotational engines with cylindrical combustion chamber:

- detonation wave propagation, cases of regular and non-regular reflection from wall (depending on the geometry);
- the influence of chamber geometry on detonation picture and specific impulse (the relative gap between cylinders, chamber's length, internal cylinder's radius).

Gas-dynamic initiation of combustion and detonation processes in channels with various geometry. Interaction of shock wave with concave spherical surface. The research of combustible mixtures ignition under the influence of a shock wave.

Detonation initiation with laser pulse in gas and gas-disperse mixtures. The research of excitement threshold's dependency on mixture composition, pressure, laser pulse parameters. The influence of dispersed phase characteristic on lowering the breakthrough threshold compared to pure gas.

The adjustment of numerical modeling of deflagration to detonation transition (DDT):

- Application of numerical modeling methods, based on Large-Eddy Simulation (LES).
- Research of DDT in particular geometric configurations.
- Comparison with data acquired by solving Reynolds-averaged Navier-Stokes equations, limited by differential turbulence modules.

### Acknowledgments

This study was financially supported by the Ministry of Education and Science of the Russian Federation (the Agreement No. 14.575.21.0057), a unique identifier for Applied Scientific Research (project) RFMEFI57514X0057.

### Disclosure statement

No potential conflict of interest was reported by the authors.

### Notes on contributors

**Pavel V. Bulat** is a PhD, Head of the International Laboratory of Mechanics and Energy Systems, Saint Petersburg National Research University of Information Technologies, Mechanics and Optics, Saint Petersburg, Russia.

**Konstantin N. Volkov** is Doctor of Technical Sciences, Lecturer at Faculty of Science, Engineering and Computing, Kingston University, London, UK.

### References

- Alexandrov, V. G., Kraiko, A. N. & Reent, K. S.. (2001). "Mathematical model of a supersonic pulsed detonation Ramjet engine. *High Speed Deflagration and Detonation: Fundamentals and Control*, ELEX-KM Publ, Moscow, 333-344.
- Bulat, M. P. & Ilina, T. E. (2013). The problem of creating detonation engine – current trends in aerospace engine manufacturing. *Fundamental Research*, 10(10), 2140-2142.
- Bulat, P. V. (2014). About the detonation engine. *American Journal of Applied Sciences*, 11(8), 1357-1364.



- Bulat, P. V. & Prodan, N. V. (2013). Overview of projects detonation engines. Pulse ramjet engine. *Fundamental Research*, 10(8), 1667–71.
- Bykovsky, F. A., Zhdan, S. A. & Vedernikov, E. F. (2006). Continuous spin detonation of the fuel-air mixtures. *Combustion, Explosion and Shock Waves*, 4, 107–15.
- Bykovsky, F. A., Zhdan, S. A. & Vedernikov, E. F. (2010). Continuous spin detonation of hydrogen-air mixture with the addition of air in the mixing zone and products. *Combustion, Explosion and Shock Waves*, 1, 60–68.
- Bykovsky, F. A., Zhdan, S. A. & Vedernikov, E. F. (2013). Reactive thrust during continuous detonation in the mode of air ejection. *Combustion, Explosion and Shock Waves*, 2, 71–79.
- Cambier, J. L., Adelman, H. & Menees, G. P. (1990). Numerical simulations of an oblique detonation wave engine. *Journal of Propulsion and Power*, 6(3), 315–23.
- Davidenko, D., Gökalp, I. & Falempin, F. (2011). Theoretical performance of rocket and turbojet engines operating in the continuous detonation mode. *Proceedings of 4th European Conference for Aerospace Sciences*, 8 p.
- Davidenko, D., Gökalp, I. & Kudryavtsev, A. (2008). Numerical study of the continuous detonation wave rocket engine. *Proceedings of 15th AIAA international space planes and hypersonic systems and technologies conference. AIAA Paper*, 2668-2680.
- Dunlap, R., Brehm, R. L. & Nicholls, J. A. (1958). A preliminary study of the application of steady-state detonative combustion to a reaction engine. *Jet Propulsion*, 28, 451–56.
- Eidelman, S. & Grossman, W. (1992). Pulsed detonation engine: experimental and theoretical review. *Proceedings of 28th Joint Propulsion Conference and Exhibit. AIAA Paper*, 92–3168.
- Falempin, F., Daniau, E., Getin, N., Bykovskii, F. & Zhdan, S. (2006). Toward a continuous detonation wave rocket engine demonstrator. *Proceedings of 4th AIAA/AHI Space Planes and Hypersonic Systems and Technologies Conference. AIAA Paper*, 7938-7956.
- Helman, D., Shreeve, R. P. & Eidelman, S. (1986). Detonation pulse engine. *AIAA Paper*, 86, 1683.
- Hishida, M., Fujiwara, T. & Wolanski, P. (2009). Fundamentals of rotating detonations. *Shock Waves*, 19(1), 1–10.
- Ivanov, M. S., Kudryavtsev, A. N., Trocyk, A. V. & Fomin, V. M. (2006). A way of detonation combustion regime organizing in the combustion chamber of a supersonic ramjet engine. *ITPM. Russian Federation patent*, 2285143.
- Jeung, I. S., Choi, J. Y. & Yoon, Y. (1998). Numerical study of scram accelerator starting characteristics. *AIAA Journal*, 36(6), 1029–38.
- Kawane, K., Shimada, S., Kasahara, J. & Matsuo, A. (2011). The influence of heat transfer and friction on the impulse of a detonation tube. *Combustion and Flame*, 158(10), 2023–36.
- Kindracki, J., Wolański, P. & Gut, Z. (2011). Experimental research on the rotating detonation in gaseous fuels–oxygen mixtures. *Shock Waves*, 21(2), 75–84.
- Larionov, S. Yu., Nechaev, Yu. N. & Mokhov, A. A. (2007). Research and analysis of the “cold” purging of high frequency pulse detonation engine traction unit. *Bulletin of the Moscow Aviation Institute*, 14(4), 36–41.
- Lee, S., Cho, D. R. & Choi J. Y. (2008). Effect of curvature on the detonation wave propagation characteristics in annular channels. *Proceedings of 46th AIAA Aerospace Sciences Meeting and Exhibit, AIAA Paper*, 2008–2988.
- Levin, V. A., Nechaev, Yu. I. & Tarasov, A. I. (2001). A new approach to organization of pulse detonation engine working process. *Russian Journal of Physical Chemistry*, 20(6), 90–98.
- Levin, V. A., Smekhov, G. D., Tarasov, A. I. & Khmelevsky, A. N. (1998). Calculated and experimental study of pulsing detonation in engine model. Moscow: Moscow State University, 358.
- Mitrofanov, V. V. & Zhdan, S. A. (2004). Thrust Performance of an Ideal Pulse Detonation Engine. *Combustion, Explosion and Shock Waves*, 40(4), 380–85.
- Nakayama, H., Moriya, T., Kasahara, J. & Matsuo, A. (2012). Stable detonation wave propagation in rectangular-cross-section curved channels. *Combustion and Flame*, 159(2), 859–69.
- Nicholls, J. A., Wilkmson, H. R. & Morrison, R. B. (1957). Intermittent detonation as a thrust-producing mechanism. *Jet Propulsion*, 21, 534–41.
- Pan, Z., Fan, B., Zhang, X., Gui, M. & Dong, G. (2011). Wavelet pattern and self-sustained mechanism of gaseous detonation rotating in a coaxial cylinder. *Combustion and Flame*, 158(11), 2220–28.

- Schauer, F., Stutrud, J. & Bradley, R. (2001). Detonation initiation studies and performance results for pulsed detonation engine applications. *Proceedings of 39th Aerospace Sciences Meeting and Exhibit (Reno)*. AIAA Paper, 2001–1129.
- Schauer, F. R., Miser, C. L., Tucker, K. C., Bradley, R. P. & Hoke, J. L. (2005). Detonation initiation of hydrocarbon-air mixtures in a pulsed detonation engine. *Proceedings of 43rd AIAA Aerospace Sciences Meeting and Exhibit*. AIAA Paper, 2005–1343.
- Schwer D., Kailasanath K. (2010). Numerical Investigation of Rotating Detonation Engines. *Proceedings of 46th AIAA/ASME/SAE/ASEE Joint Propulsion Conference*, 15.
- Schwer D., Kailasanath K. (2011). Numerical investigation of the physics of rotating-detonation-engines. *Proceedings of the Combustion Institute*, 33(2), 2195–2202.
- Schwer, D. & Kailasanath, K. (2013). Fluid dynamics of rotating detonation engines with hydrogen and hydrocarbon fuels. *Proceedings of the Combustion Institute*, 34(2), 1991–98.
- Shaoa, Y. T., Liua, M. & Wang, J. P. (2010). Numerical investigation of rotating detonation engine propulsive performance. *Combustion Science and Technology*, 182(12), 1586–97.
- Ting, J. M., Bussing, T. R. & Hinkey, J. B. (1995). Experimental characterization of the detonation properties of hydrocarbon fuels for the development of a Pulse Detonation Engine. *Proceedings of 31st Joint Propulsion Conference and Exhibit*, AIAA Paper, 3095–3154.
- Tsuboi, N., Eto, K. & Hayashi, A. K. (2007). Detailed structure of spinning detonation in a circular tube. *Combustion and Flame*, 149(2), 144–61.
- Uemura, Y., Hayashi, A. K. & Asahara, M. (2013). Transverse wave generation mechanism in rotating detonation. *Proceedings of the Combustion Institute*, 34(2), 1981–89.
- Voitsekhovskiy, B. V., Mitrofanov, V. V. & Topchiyan, M. E. (1963). *The Structure of the Detonation Front in Gases*. Novosibirsk. USSR Academy of Science press, 167 p.
- Yageta, J., Shimada, S. & Matsuoka, A. (2011). Combustion wave propagation and detonation initiation in the vicinity of closed-tube end walls. *Proceedings of the Combustion Institute*, 33(2), 2303–10.
- Zhou, R. & Wang, J. (2012). Numerical investigation of flow particle paths and thermodynamic performance of continuously rotating detonation engines. *Combustion and Flame*, 159(12), 3632–3645.
- Zhou, R., Wang, J. & Wu, D. (2012). Three-dimensional Phenomenon of Continuously Rotating Detonation Engines. *Proceedings of 7th International Conference on Computational Fluid Dynamics*, 6-10.
- Zhou, R. & Wang, J. P. (2013). Numerical investigation of shock wave reflections near the head ends of rotating detonation engines. *Shock Waves*, 23(5), 461–72.
- Zhukov, V. P. & Starikovskii, A. Yu. (2005). Deflagration-to-detonation control by non-equilibrium gas discharges and its applications for pulsed detonation engine. *Proceedings of 43rd AIAA Aerospace Sciences Meeting and Exhibit*, 11-16.